

平面圖

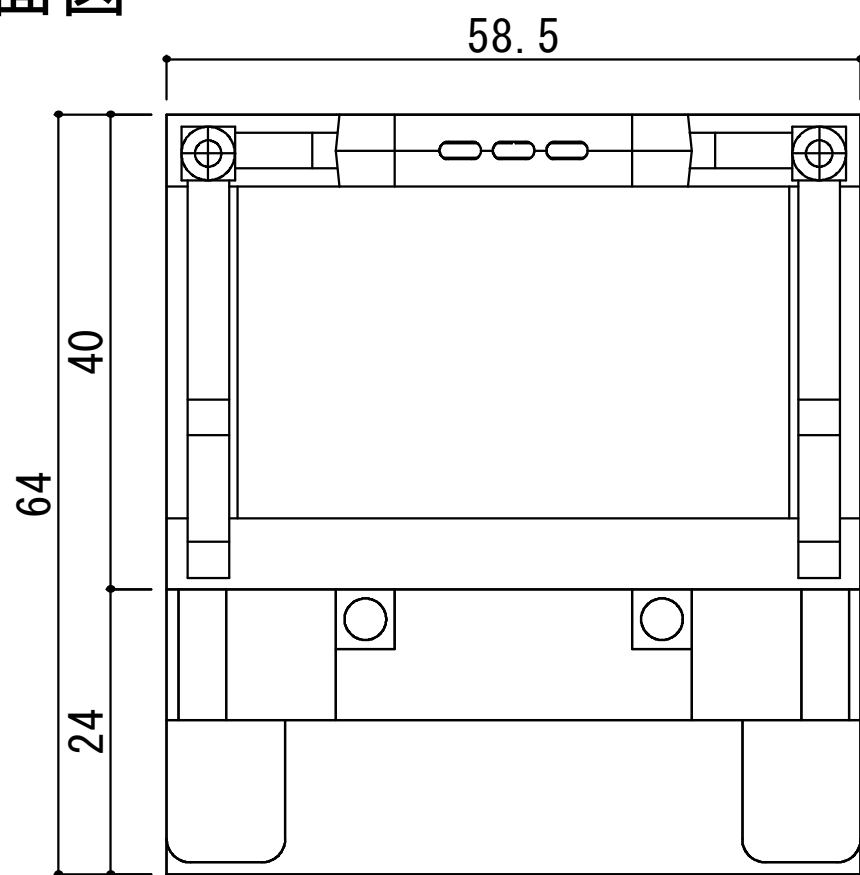

背面圖

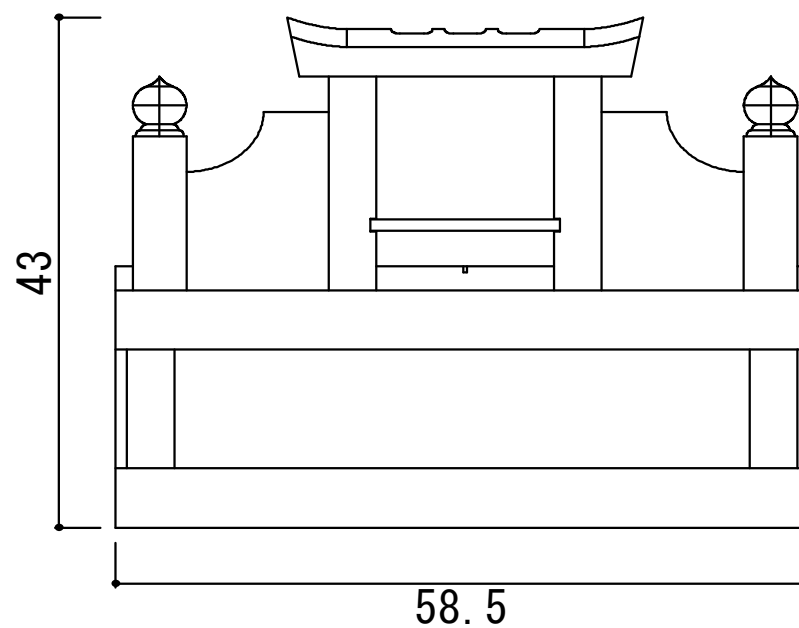

正面圖

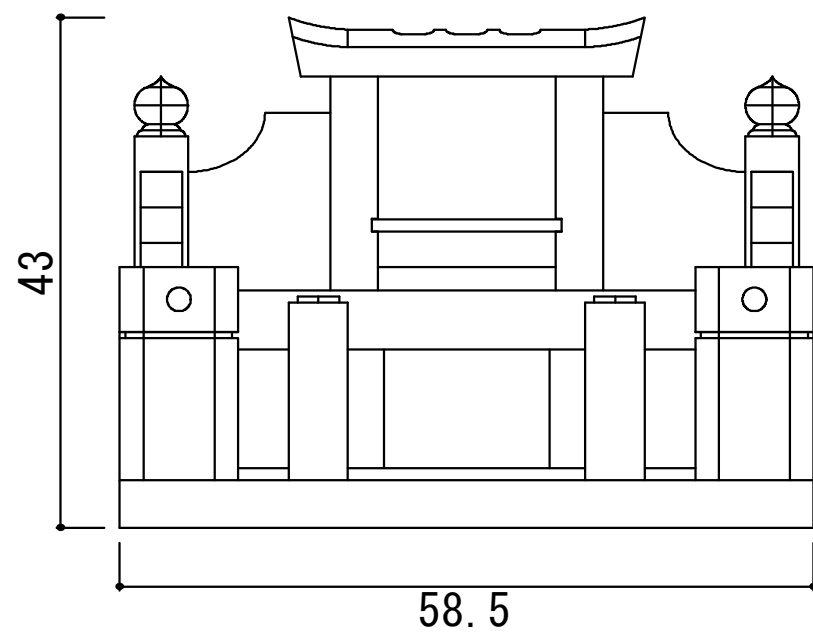

側面圖

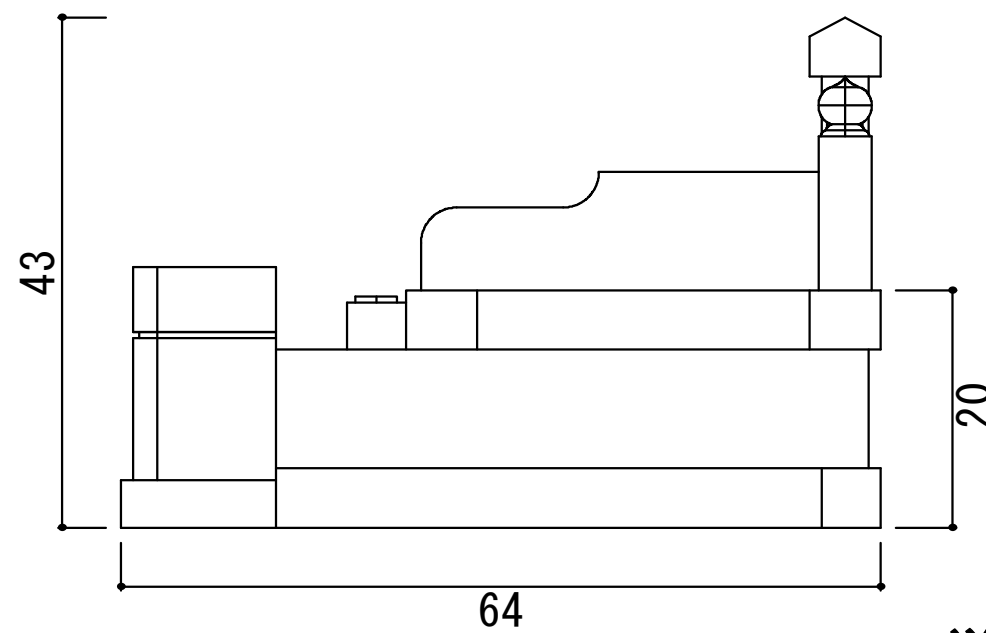

單位：寸